



3-dimensional digital reconstructions and interactive exhibits at the Museum of Industrial Olive Oil Production, Greece

<http://www.makebelieve.gr>

We are pleased to announce the opening of the new Museum of Industrial Olive Oil Production, which is housed in a traditional olive oil production plant on the island of Lesbos in Greece. The Museum will be inaugurated on September 15, 2006 by the President of the Hellenic Republic, Mr. Karolos Papoulias.

makebelieve design & consulting has designed and developed the digital exhibits for the new Museum, creating a series of digital productions which incorporate the 3D digital reconstruction of the fascinating industrial-era machinery. Most notably, the film *"From water to water"* includes the accurate 3D modelling of the steam engine, with animation that illustrates the process of energy production; the film *"From olives to olive oil"* includes accurate 3D reconstructions of the olive presses and their pumps, with animation illustrating the grinding, compression, and separation process for olive oil production. The productions are projected on multiple screens alongside the exhibits and on various informational panels throughout the exhibition spaces.

makebelieve has also designed and developed interactive exhibits for visitors of all ages, which are installed in the Museum's educational rooms. The educational game *"Oil the 'wheels' of the communal engine"* allows young visitors to construct the engines used for producing olive oil and learn about the process in an engaging and challenging way.

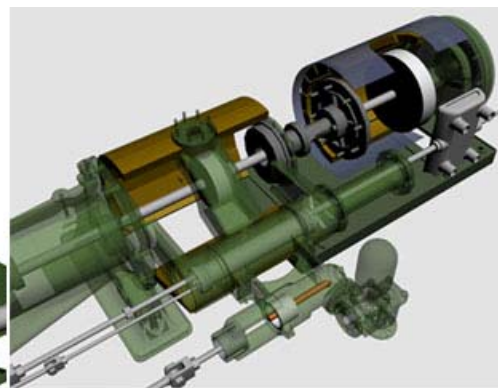
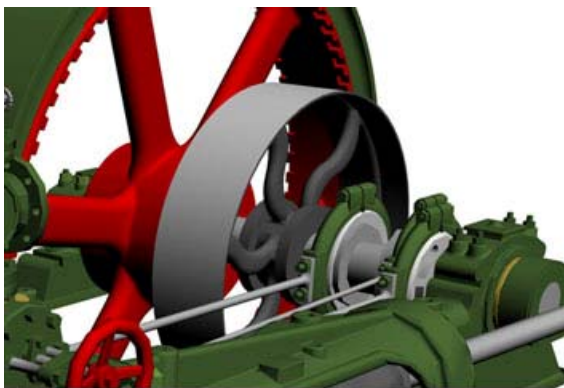

About the **Museum of Industrial Olive Oil Production**:

The formal inauguration of the Museum of Industrial Olive Oil Production of Lesvos will be undertaken by the President of the Hellenic Republic Mr. Karolos Papoulias on Friday 15 September 2006 at 12.30 pm., Aghia Paraskevi, 811 02 Lesvos, Tel. +30 22350 32300.

The Museum of Industrial Olive Oil Production of Lesvos is part of the Museums Network of the **Pireaus Bank Group Cultural Foundation**. The Foundation organises and manages a network of thematic museums which currently includes Museum of the Olive and Greek Olive Oil in Sparta, the Open-air Water Power Museum in Dimitsana, the Museum of Greek Musical Instruments, and the Silk Museum in Soufli. The Museums Network is constantly expanding with new museums around Greece (e.g., the Museum of Marble working in Tinos, the Museum of Traditional Trades/Crafts and Environment in the Stymfalia lake, etc.).

For more information: <http://www.piop.gr/>, e-mail: piop@pireausbank.gr, Tel. +30 210 3216352.

About **makebelieve**:

makebelieve is an interactive design and consulting company based in Greece and the UK. Our work involves the conceptualisation and design of user-centred, functional and engaging immersive and interactive digital experiences, drawing on contemporary research and emerging practice in the area of educational and cultural technology, entertainment, and marketing.

makebelieve's activities encompass a range of topics concerning the initial concept development, design, coordination, and evaluation of innovative digital media experiences and high-end immersive Virtual Reality projects as well as multimedia and web design work for a diverse clientele. Clients include public and private institutions, museums, location-based entertainment research, and commercial spaces.

Recent projects include the design and development of an educational website for the Hellenic Ministry of Culture concerning the Byzantine archeological site of Mystras, the design of numerous sites and productions for artists, the design, development, and installation of interactive virtual reality environments for entertainment and research purposes, and involvement in EU-funded research projects.

For more information, see <http://www.makebelieve.gr/>, or e-mail: info@makebelieve.gr

-//-